

記 事 DESCRIPTION	
1. サーマルプロテクター	
1-1. 動作温度: 120	5
1-2. 復帰温度: 80	15

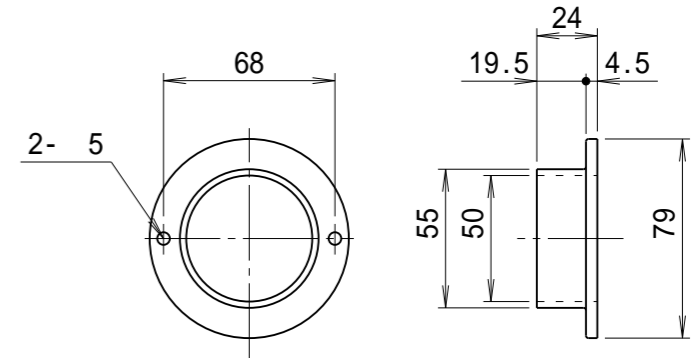

吸込口金詳細図(1/3)

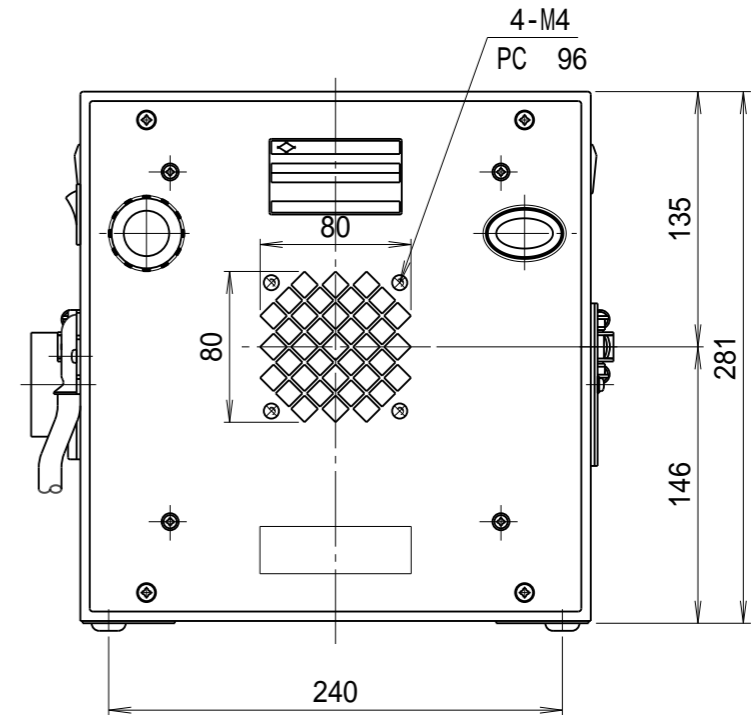
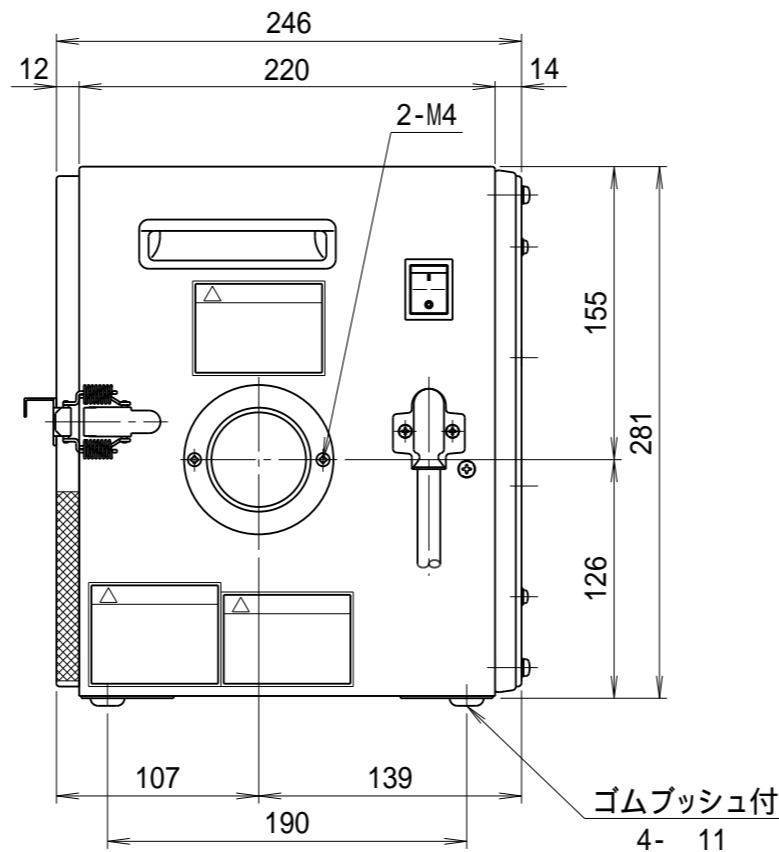
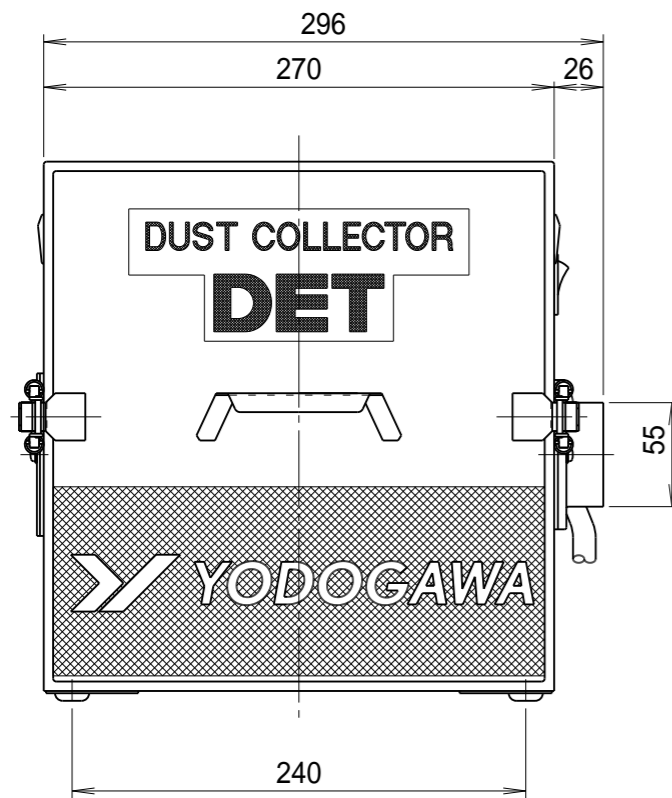

				仕 様 SPECIFICATIONS			日 付 DATE	尺 度 SCALE	第3角法 3RD ANGLE PROJECTION	型 式 TYPE					
				電 動 機 MOTOR OUT PUT	50W 2P	周 波 数 (Hz) FREQUENCY	50	60		DET100B-HP					
				電 源 電 圧 POWER SUPPLY	3 200V	回 転 数 (min ⁻¹) REVOLUTION	2850	3300							
				集 塵 容 量 CAPACITY	0.5リットル	電 流 (A) CURRENT	0.4	0.3							
				絶 縁 等 級 INS. CLASS	E	静 圧 (kPa) STATIC PRESS.	0.35	0.50							
				塗 装 色 COATING COLOR	5.8Y7.7/1.3	風 量 (m ³ /min) AIR CAPACITY	1.1	1.3							
						質 量 (kg) WEIGHT	10.8								
無印 MARK	2017.10.17 DATE	平面図の追加 REVISIONS	江口 REVISED				製 図 DRAWN	江口	検 査 CHECKED	踞尾	承 認 APPROVED	単 位 UNIT	mm	名 称 NAME	超小型HEPAクラス排気 カートリッジフィルター集塵機
													図 番 DWG. NO.	D52641	
YODOGAWA ELECTRIC TOOL MFG.CO.															